



BUILDING 1

GAURD HOUSE

EXIST BUILDING OUTLINE

S200K ACO SLOPED CHANNEL GRATED DRAIN WITH CONNECTION TO EXISTING DOWNSTREAM PIT.

EXISTING PIT LIDS TO BE CONVERTED TO MATCH NEW KERB. REFER TO ARP-XX-XX-DR-C-6091 FOR DETAILS.

S200K ACO SLOPED CHANNEL GRATED DRAIN WITH CONNECTION TO EXISTING DOWNSTREAM PIT.

EXISTING TRUNK DRAINAGE PIT LIDS TO BE ADJUSTED TO NEW SURFACE LEVELS. REFER DRAWING No. ARU-XX-XX-DR-C-6048 & 6049 FOR LONGSECTIONS

EXISTING WATER QUALITY TREATMENT FILTER CHAMBER BY OTHERS. REFER TO DRAWINGS AUR-XX-XX-DR-C-6026 & 6027 FOR DETAILS.

EXISTING SECTION OF PIPE TO BE REMOVED

DIRECT PIPE TO PIPE CONNECTION TO EXISTING DRAINAGE

HYDROCARBON SENSOR ALARM AND AUTOMATIC SHUT OFF VALVE INSTALLED IN PIT. SHUTOFF VALVE IS TYPICALLY OPEN AND CLOSSES UPON DETECTION OF HYDROCARBON.

CONNECTION TO EXISTING DRAINAGE

FOR FUTURE CONNECTION

RAINWATER HARVESTING TANK OVERFLOW CONNECTION POINT

EASTERN CREEK DR

SPEL PURACEPTOR P.060.L.C1.2C.A.300.PVC OIL AND WATER SEPARATOR OR OTHER APPROVED EQUIVALENT

EXISTING BCC TRUNK MAIN WITHIN EASEMENT 3 m WIDE

EXISTING TRUNK DRAINAGE PIT LIDS TO BE ADJUSTED TO NEW SURFACE LEVELS. REFER DRAWING No. ARU-XX-XX-DR-C-6048 & 6049 FOR LONGSECTIONS

CONCRETE CHANNEL OUTLET TO GRATED INLET PIT REFER TO DRAWING No. ARU-XX-XX-DR-C-6091 FOR CONCRETE CHANNEL DETAIL.

PROPOSED BUILDING FFL RL 70

TEMP SITE OFFICE BUILDING OUTLINE

"ECHIDNA"

BUILDING 1A

HYDROCARBON SENSOR ALARM AND AUTOMATIC SHUT OFF VALVE INSTALLED IN PIT. SHUTOFF VALVE IS TYPICALLY OPEN AND CLOSSES UPON DETECTION OF HYDROCARBON.

EXTENT OF PROPOSED STORMWATER TO BE CONSTRUCTED BY OTHERS PRIOR TO CONSTRUCTION OF ECHIDNA WORKS

CONNECTION FROM EXISTING DRAINAGE

EXISTING SECTION OF PIPE TO BE REMOVED AT AN APPROPRIATE STAGE OF ECHIDNA CONSTRUCTION WORKS TO CONTINUE ALLOWING FOR PROPER STORMWATER MANAGEMENT OF THE SITE.

- NOTES
- FOR GENERAL NOTES REFER DRAWING No's ARU-XX-XX-DR-C-0006 TO ARU-XX-XX-DR-C-0007.
 - FOR GENERAL LEGEND REFER DRAWING NO. ARU-XX-XX-DR-C-0011.
 - REFER TO HYDRAULIC DRAWINGS FOR BUILDING ROOF DRAINAGE.
 - FOR STORMWATER LONGITUDINAL SECTIONS REFER TO DRAWING No's ARU-XX-XX-DR-C-6041 TO ARU-XX-XX-DR-C-6049.
 - FOR STORMWATER PIT SCHEDULE REFER TO DRAWING No SYD057-ARU-XX-XX-DR-C-6081.
 - FOR STORMWATER DETAILS REFER TO DRAWING No's ARU-XX-XX-DR-C-6091 TO ARU-XX-XX-DR-C-6093.

KEYNOTES

LEGEND

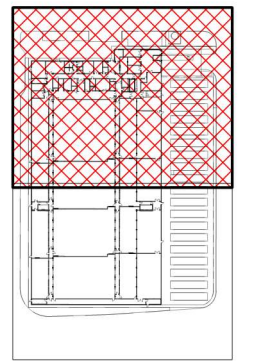

REV	DATE	DESCRIPTION	DRN	ENG	CHK	APP
D	17NOV22	TENDER SET	PA	EA	TT	LC
C	20OCT22	DESIGN DEVELOPMENT	PA	EA	TT	LC
B	01SEP22	SCHEMATIC DESIGN	PA	EA	TT	LC
A	18AUG22	ISSUED FOR SSDA	PA	EA	TT	LC
1	15JUL22	MASTERPLAN	PA	EA	TT	LC

CONSULTING ENGINEERS

ARUP

ARCHITECT

GENTON

PROJECT: ECHIDNA

TITLE: STORMWATER PLAN SHEET 1

DRAWING NO.: ARP-XX-XX-DR-C-6001

SCALE: 1:250m

AGILE No.: A1

REV: D

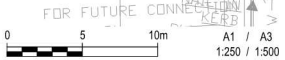

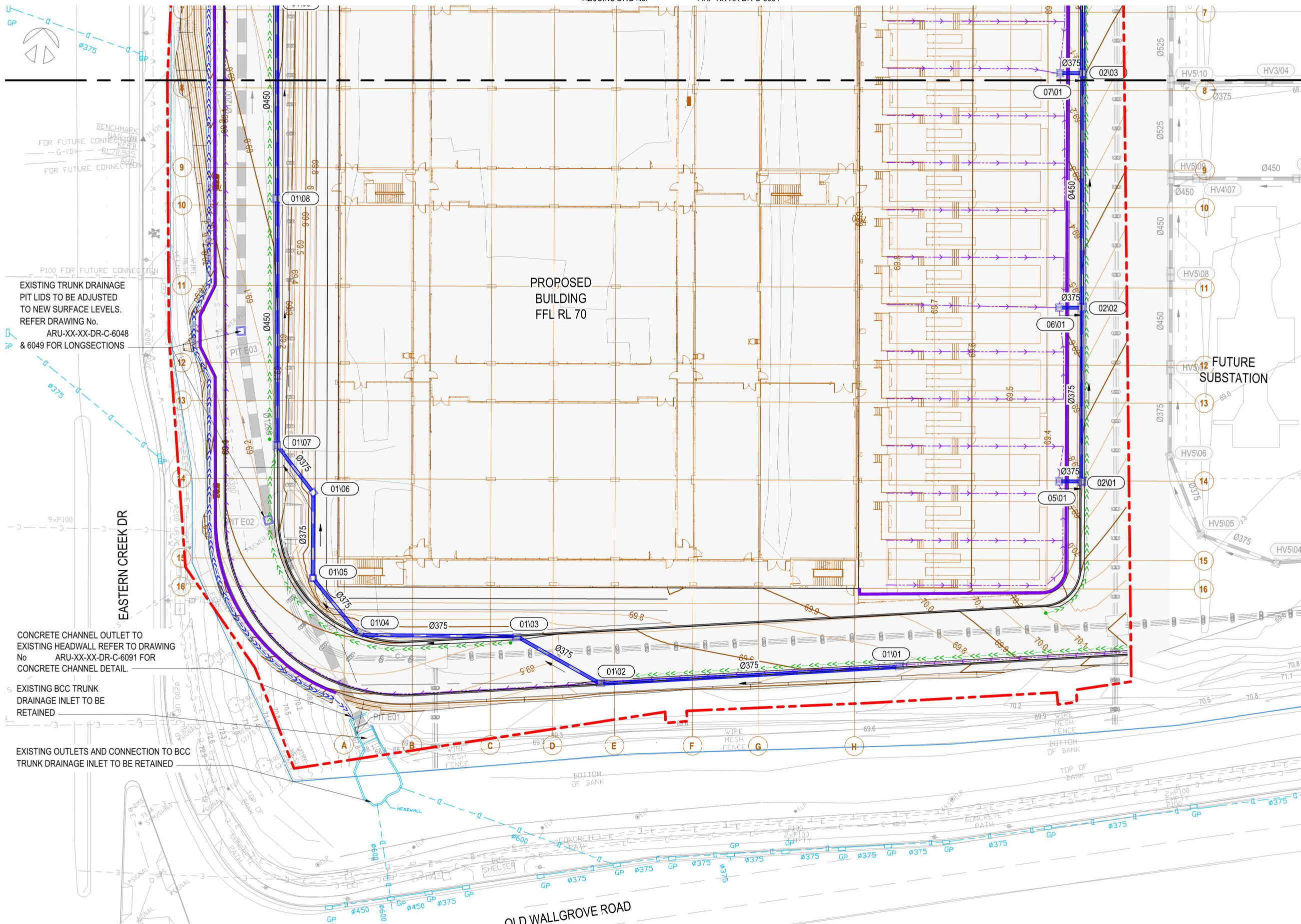

- NOTES
- FOR GENERAL NOTES REFER DRAWING No's ARU-XX-XX-DR-C-0006 TO ARU-XX-XX-DR-C-0007.
 - FOR GENERAL LEGEND REFER DRAWING NO. ARU-XX-XX-DR-C-0011.
 - REFER TO HYDRAULIC DRAWINGS FOR BUILDING ROOF DRAINAGE.
 - FOR STORMWATER LONGITUDINAL SECTIONS REFER TO DRAWING No's ARU-XX-XX-DR-C-6041 TO ARU-XX-XX-DR-C-6049.
 - FOR STORMWATER PIT SCHEDULE REFER TO DRAWING No SYD057-ARU-XX-XX-DR-C-6081.
 - FOR STORMWATER DETAILS REFER TO DRAWING No's ARU-XX-XX-DR-C-6091 TO ARU-XX-XX-DR-C-6093.

KEYNOTES

LEGEND

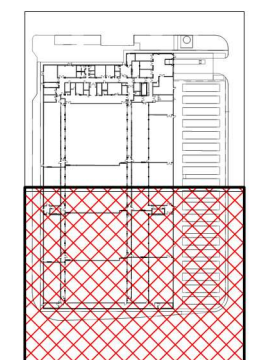

EXISTING TRUNK DRAINAGE PIT LIDS TO BE ADJUSTED TO NEW SURFACE LEVELS. REFER DRAWING No. ARU-XX-XX-DR-C-6048 & 6049 FOR LONGSECTIONS

CONCRETE CHANNEL OUTLET TO EXISTING HEADWALL REFER TO DRAWING No ARU-XX-XX-DR-C-6091 FOR CONCRETE CHANNEL DETAIL.

EXISTING BCC TRUNK DRAINAGE INLET TO BE RETAINED

EXISTING OUTLETS AND CONNECTION TO BCC TRUNK DRAINAGE INLET TO BE RETAINED

REV	DATE	DESCRIPTION	DRN	ENG	CHK	APP
D	17NOV22	TENDER SET	PA	EA	TT	LC
C	20OCT22	DESIGN DEVELOPMENT	PA	EA	TT	LC
B	01SEP22	SCHEMATIC DESIGN	PA	EA	TT	LC
A	18AUG22	ISSUED FOR SSDA	PA	EA	TT	LC
1	15JUL22	MASTERPLAN	PA	EA	TT	LC

CONSULTING ENGINEERS

ARUP

ARCHITECT

GENTON

PROJECT: ECHIDNA

TITLE: STORMWATER PLAN SHEET 2

DRAWING NO.: ARP-XX-XX-DR-C-6002

SCALE: A1 1:250m

AGILE No.:

REV: D



BUILDING 1

GAARD HOUSE

EXIST BUILDING OUTLINE

NOTES

KEYNOTES

LEGEND

FOR FUTURE CONNECTION

FOR FUTURE CONNECTION

EASTERN CREEK DR

FOR FUTURE CONNECTION

FOR FUTURE CONNECTION

0 5 10m
A1 / A3
1:250 / 1:500

01109
0.0421ha

03101

01111
0.0045ha

09101
0.0417ha

01112
0.0068ha

02113
0.0171ha

10101
0.0066ha

10102

01113

02114

09102

02112

02112
0.0533ha

02111

02111
0.0358ha

02110

02110
0.0258ha

02109

02109
0.0372ha

02108

02108
0.0106ha

02107

02106

02105

02105
0.0695ha

02104

02104

02103

04101

04100

08101(2)
0.1552ha

08101

08101
0.1364ha

08101

07101(2)
0.0986ha

07101

07101
0.0685ha

07101

01112(2)
0.4704ha

01112

01110
0.0462ha

01110

01109

01109

01109

01109

01109

01109

01109

01109

01109

01109

01109

01109

01109

01109

01109

01109

01109

01109

01109

01109

01109

01109

01109

01109

01109

01109

01109

01109

01109

01109

01109

01109

01109

01109

01109

01109

01109

01109

01109

01109

01109

01109

01109

01109

PROPOSED BUILDING
FFL RL 70

TEMP SITE OFFICE
BUILDING OUTLINE

"ECHIDNA"

BUILDING 1A

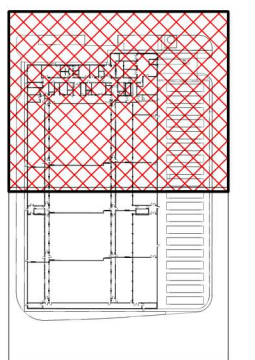

REV	DATE	DESCRIPTION	DRN	ENG	CHK	APP
D	17NOV22	TENDER SET	PA	EA	TT	LC
C	20OCT22	DESIGN DEVELOPMENT	PA	EA	TT	LC
B	01SEP22	SCHEMATIC DESIGN	PA	EA	TT	LC
A	18AUG22	ISSUED FOR SSDA	PA	EA	TT	LC

CONSULTING ENGINEERS

ARUP

ARCHITECT

GENTON

PROJECT: ECHIDNA

TITLE: STORMWATER CATCHMENT PLAN SHEET 1

DRAWING NO.: ARP-XX-XX-DR-C-6011

SCALE: A1 1:250m

AGILE No.:

REV: D

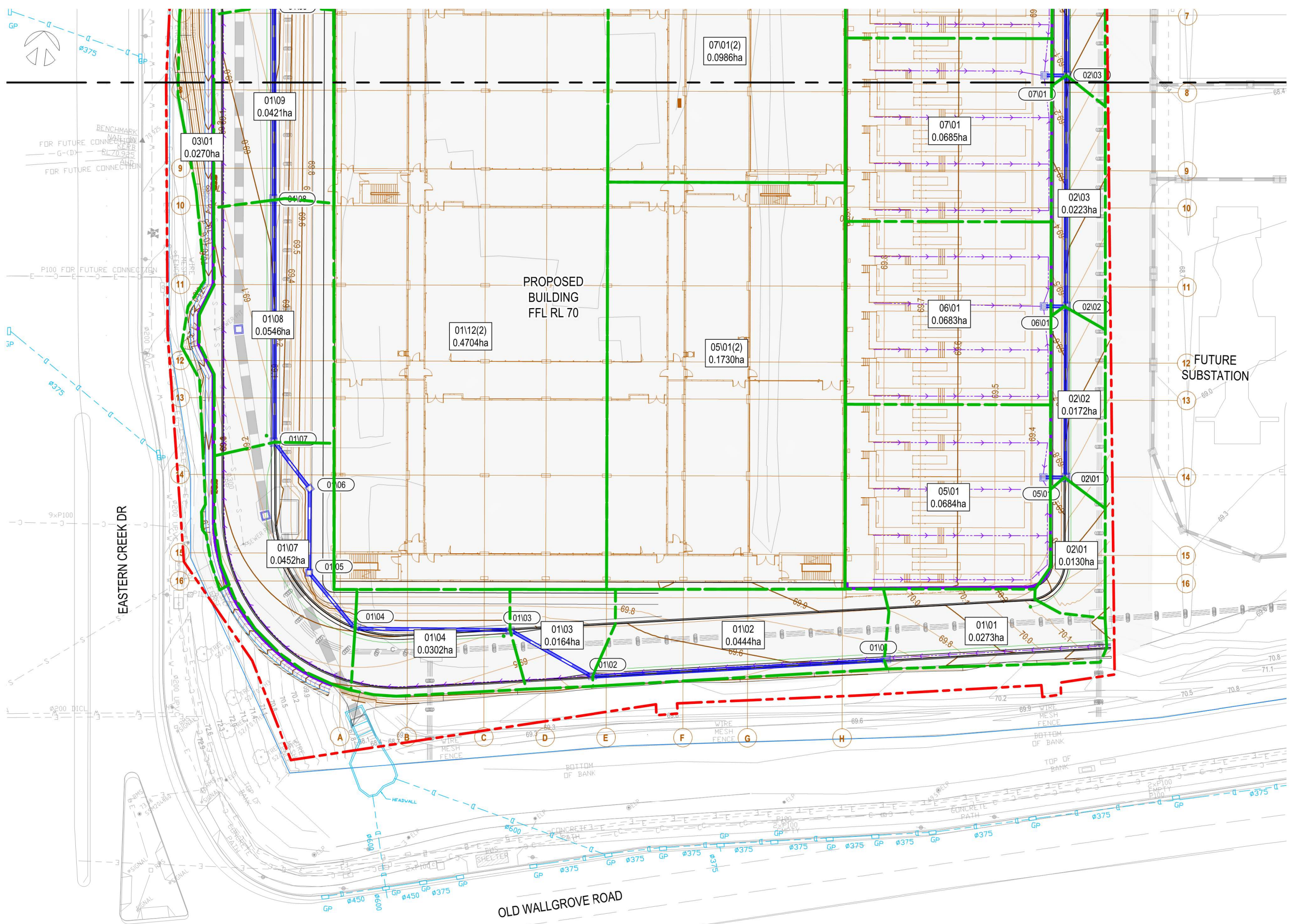

NOTES

KEYNOTES

LEGEND

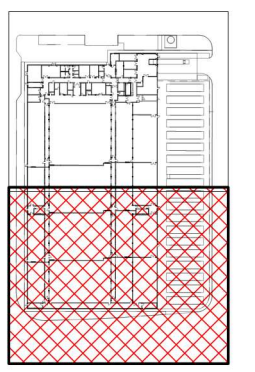

REV	DATE	DESCRIPTION	DRN	ENG	CHK	APP
D	17NOV22	TENDER SET	PA	EA	TT	LC
C	20OCT22	DESIGN DEVELOPMENT	PA	EA	TT	LC
B	01SEP22	SCHEMATIC DESIGN	PA	EA	TT	LC
A	18AUG22	ISSUED FOR SSDA	PA	EA	TT	LC

CONSULTING ENGINEERS

ARUP

ARCHITECT

GENTON

PROJECT: ECHIDNA

TITLE: STORMWATER CATCHMENT PLAN SHEET 2

DRAWING NO.: ARP-XX-XX-DR-C-6012

SCALE: A1 1:250m AGILE No.: REV: D

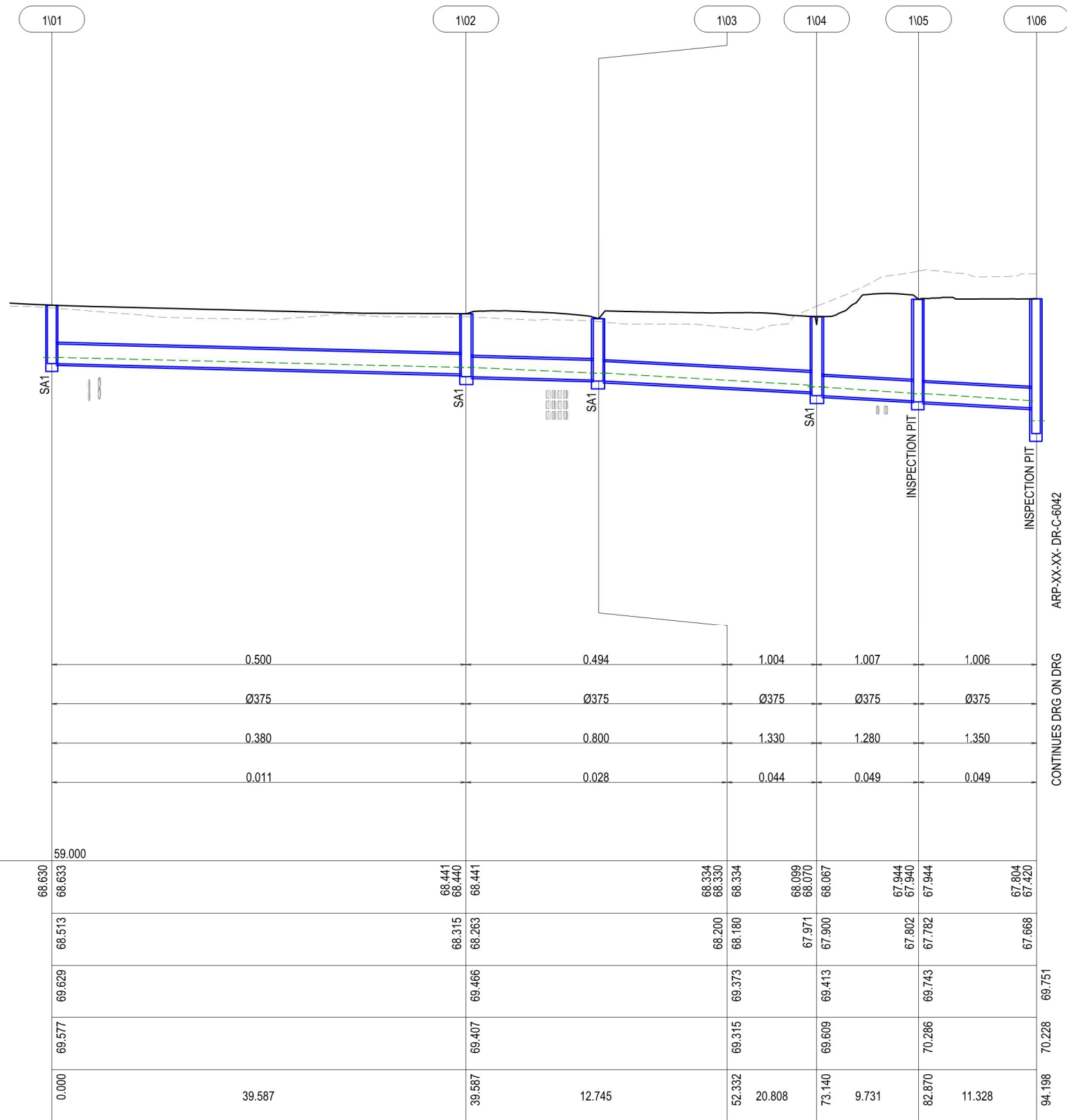

LINE 1
H 1:250
V 1:50

CONTINUES DRG ON DRG
ARP-XX-XX-DR-C-6042

- NOTES
- FOR GENERAL NOTES REFER DRAWING No's ARU-XX-XX-DR-C-0006 TO ARU-XX-XX-DR-C-0007.
 - ALL PROPOSED STORMWATER AND SEWER PIPES TO BE CLASS 4 RCP UNO.

KEYNOTES

- LEGEND
- UTILITIES
- EXISTING UTILITIES
 - ELECTRICAL - MV
 - ELECTRICAL - LV
 - COMMUNICATION - METRO FIBRE
 - COMMUNICATION - ELV
 - FIREWATER
 - WATER
 - SEWER

REV	DATE	DESCRIPTION	DRN	ENG	CHK	APP
D	17NOV22	TENDER SET	PA	EA	TT	LC
C	20OCT22	DESIGN DEVELOPMENT	PA	EA	TT	LC
B	01SEP22	SCHEMATIC DESIGN	PA	EA	TT	LC
A	18AUG22	ISSUED FOR SSDA	PA	EA	TT	LC

CONSULTING ENGINEERS

ARUP

ARCHITECT

GENTON

PROJECT: ECHIDNA

TITLE: STORMWATER LONGITUDINAL SECTION SHEET 1

DRAWING NO.: ARP-XX-XX-DR-C-6041

SCALE: NOT TO SCALE

AGILE No.: A1

REV: D



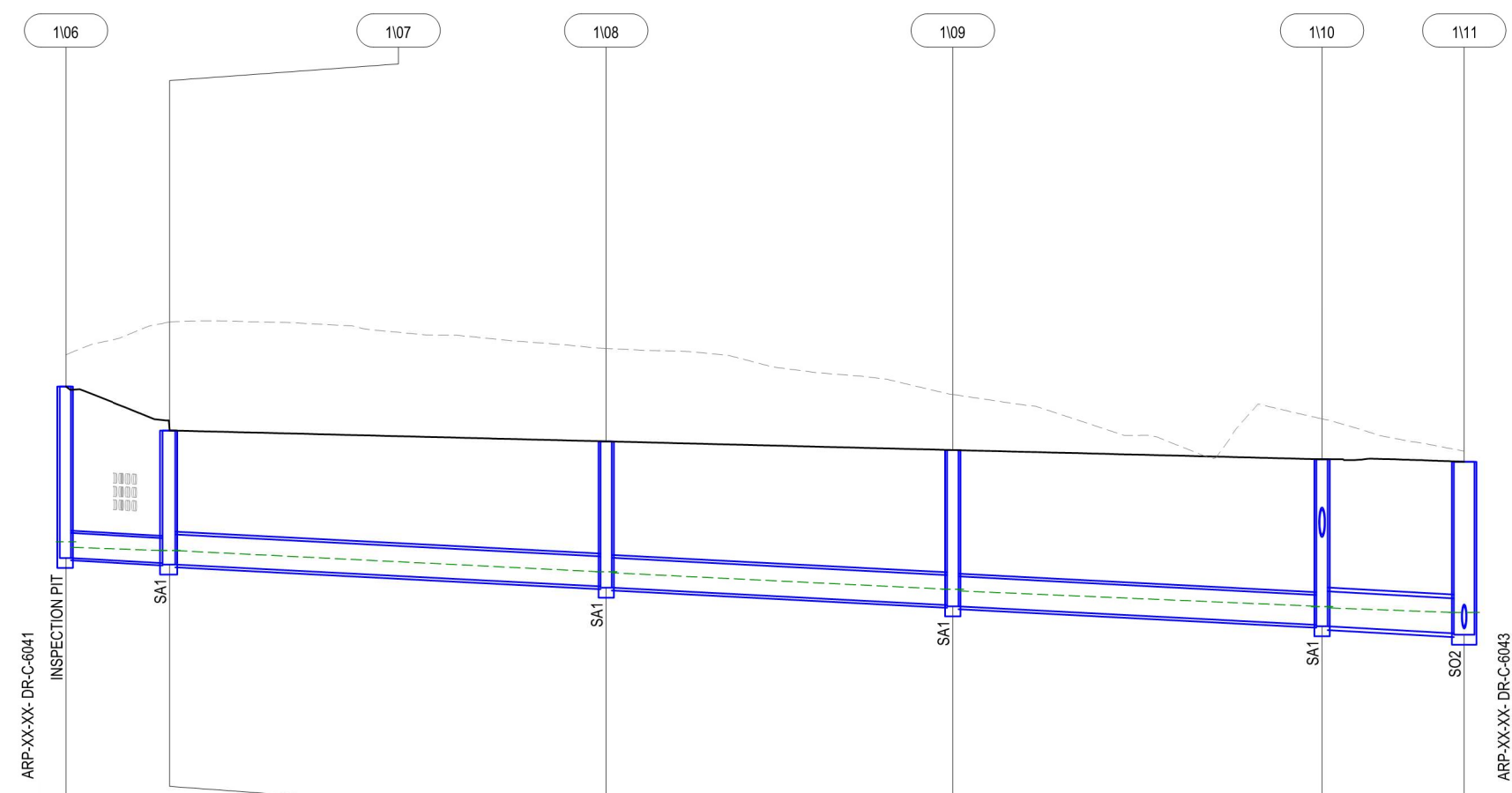

PIPE GRADE (%)
 PIPE DIAMETER (mm)
 5% AEP PIPE VELOCITY (m/s)
 5% AEP PIPE FLOW (m³/s)

DATUM R.L.
 HYDRAULIC GRADE LINE (m)
 (5% AEP)
 PIPE INVERT LEVELS (m)

DESIGN LEVELS (m)
 EXISTING LEVELS (m)

CHAINAGE (m)

CHAINAGE (m)	PIPE GRADE (%)	PIPE DIAMETER (mm)	5% AEP PIPE VELOCITY (m/s)	5% AEP PIPE FLOW (m ³ /s)	DATUM R.L.	HYDRAULIC GRADE LINE (m) (5% AEP)	PIPE INVERT LEVELS (m)	DESIGN LEVELS (m)	EXISTING LEVELS (m)	CHAINAGE (m)
94.198					59.000	67.804 67.420	67.668 67.178	69.751	70.228	94.198
101.842	0.994	Ø375	1.080	0.049		67.289 67.290	67.100 67.080	69.091	70.722	102.042
134.767	1.002	Ø450	0.890	0.065		66.970 66.956	66.752 66.732	68.928	70.323	134.767
160.814	1.002	Ø450	1.070	0.085		66.709 66.710	66.471 66.451	68.798	69.632	160.814
188.560	1.002	Ø450	1.220	0.102		66.454 66.450	66.173 66.153	68.658	69.267	188.560
199.216	1.004	Ø525	1.140	0.132		66.360	66.046	68.621	68.781	199.216

LINE 1
 H 1:250
 V 1:50

- NOTES
- FOR GENERAL NOTES REFER DRAWING No's ARU-XX-XX-DR-C-0006 TO ARU-XX-XX-DR-C-0007.
 - ALL PROPOSED STORMWATER AND SEWER PIPES TO BE CLASS 4 RCP UNO.

KEYNOTES

- LEGEND
- UTILITIES
- EXISTING UTILITIES
 - ELECTRICAL - MV
 - ELECTRICAL - LV
 - COMMUNICATION - METRO FIBRE
 - COMMUNICATION - ELV
 - FIREWATER
 - WATER
 - SEWER

REV	DATE	DESCRIPTION	DRN	ENG	CHK	APP
D	17NOV22	TENDER SET		PA	EA	TT LC
C	20OCT22	DESIGN DEVELOPMENT		PA	EA	TT LC
B	01SEP22	SCHEMATIC DESIGN		PA	EA	TT LC
A	18AUG22	ISSUED FOR SSDA		PA	EA	TT LC

CONSULTING ENGINEERS

ARUP

ARCHITECT

GENTON

PROJECT: ECHIDNA

TITLE: STORMWATER LONGITUDINAL SECTION SHEET 2

DRAWING NO.: ARP-XX-XX-DR-C-6042

SCALE: NOT TO SCALE AGILE No.: REV: D



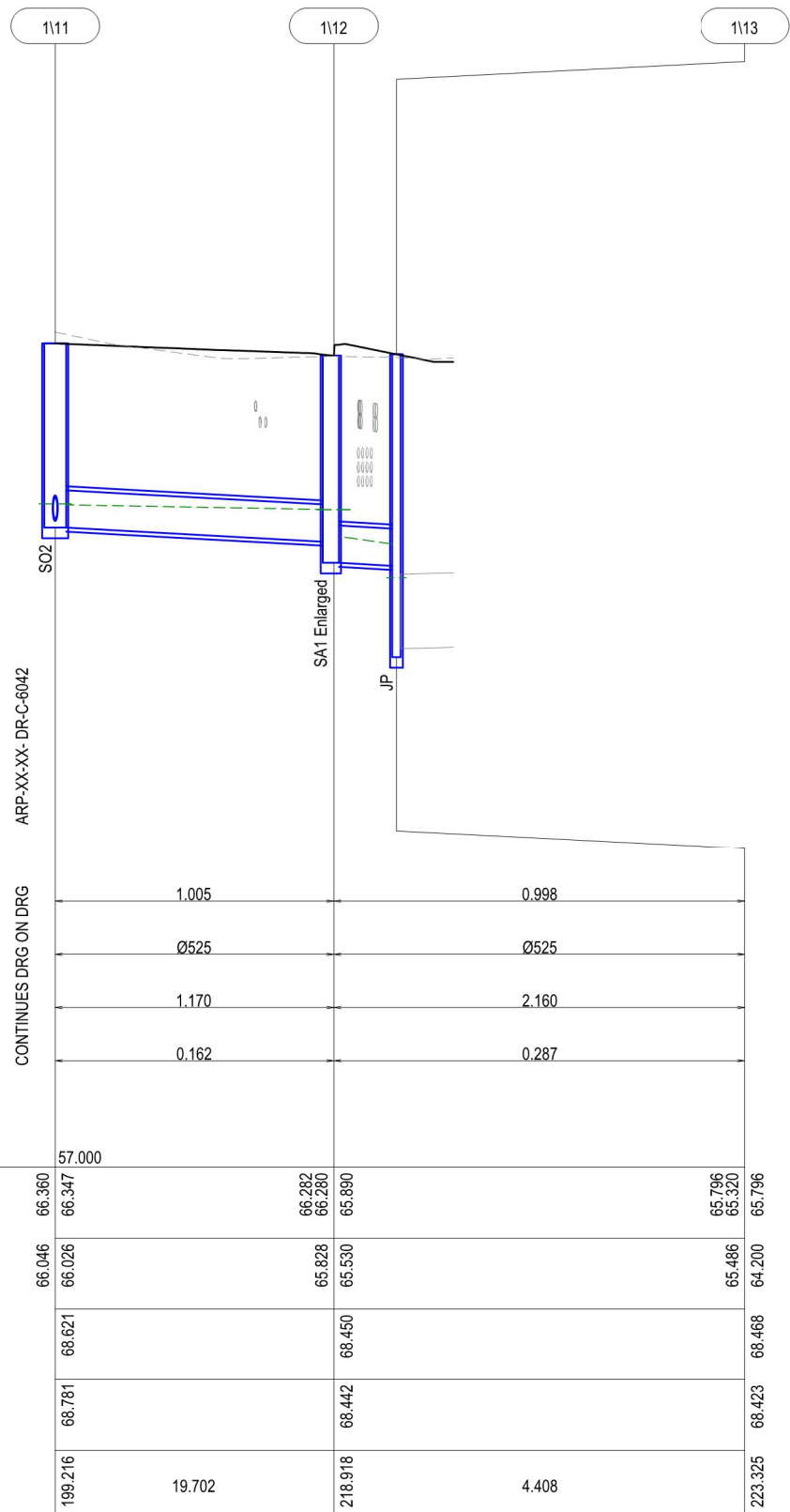

LINE 1
H 1:250
V 1:50

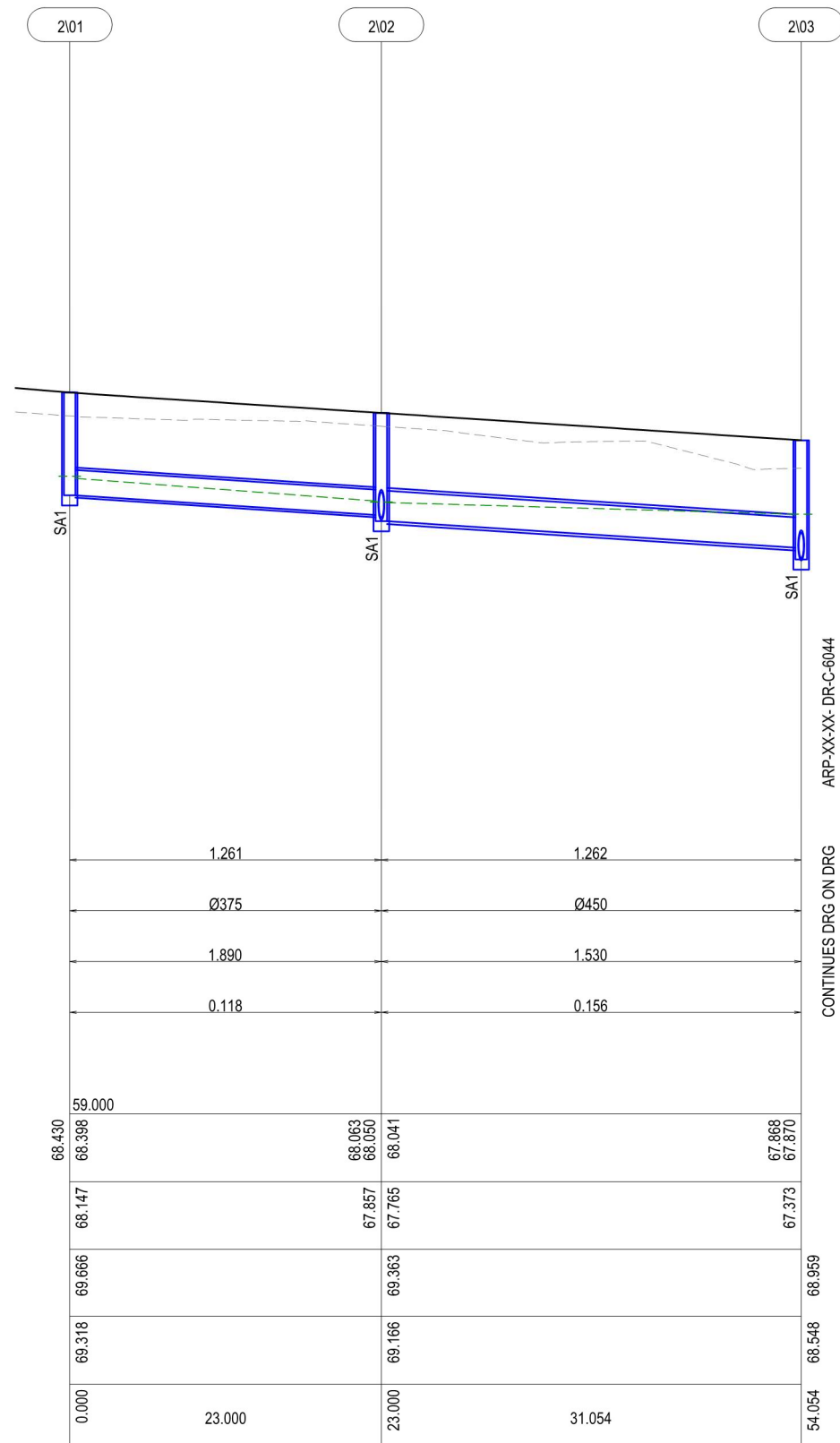

LINE 2
H 1:250
V 1:50

PIPE GRADE (%)

PIPE DIAMETER (mm)

5% AEP PIPE VELOCITY (m/s)

5% AEP PIPE FLOW (m³/s)

DATUM R.L.

HYDRAULIC GRADE LINE (m) (5% AEP)

PIPE INVERT LEVELS (m)

DESIGN LEVELS (m)

EXISTING LEVELS (m)

CHAINAGE (m)

- NOTES
- FOR GENERAL NOTES REFER DRAWING No's ARU-XX-XX-DR-C-0006 TO ARU-XX-XX-DR-C-0007.
 - ALL PROPOSED STORMWATER AND SEWER PIPES TO BE CLASS 4 RCP UNO.

KEYNOTES

- LEGEND
- UTILITIES
- EXISTING UTILITIES
 - ELECTRICAL - MV
 - ELECTRICAL - LV
 - COMMUNICATION - METRO FIBRE
 - COMMUNICATION - ELV
 - FIREWATER
 - WATER
 - SEWER

REV	DATE	DESCRIPTION	DRN	ENG	CHK	APP
D	17NOV22	TENDER SET	PA	EA	TT	LC
C	20OCT22	DESIGN DEVELOPMENT	PA	EA	TT	LC
B	01SEP22	SCHEMATIC DESIGN	PA	EA	TT	LC
A	18AUG22	ISSUED FOR SSDA	PA	EA	TT	LC

CONSULTING ENGINEERS

ARUP

ARCHITECT

GENTON

PROJECT: ECHIDNA

TITLE: STORMWATER LONGITUDINAL SECTION SHEET 3

DRAWING NO.: ARP-XX-XX-DR-C-6043

SCALE: NOT TO SCALE

AGILE No.: A1

REV: D



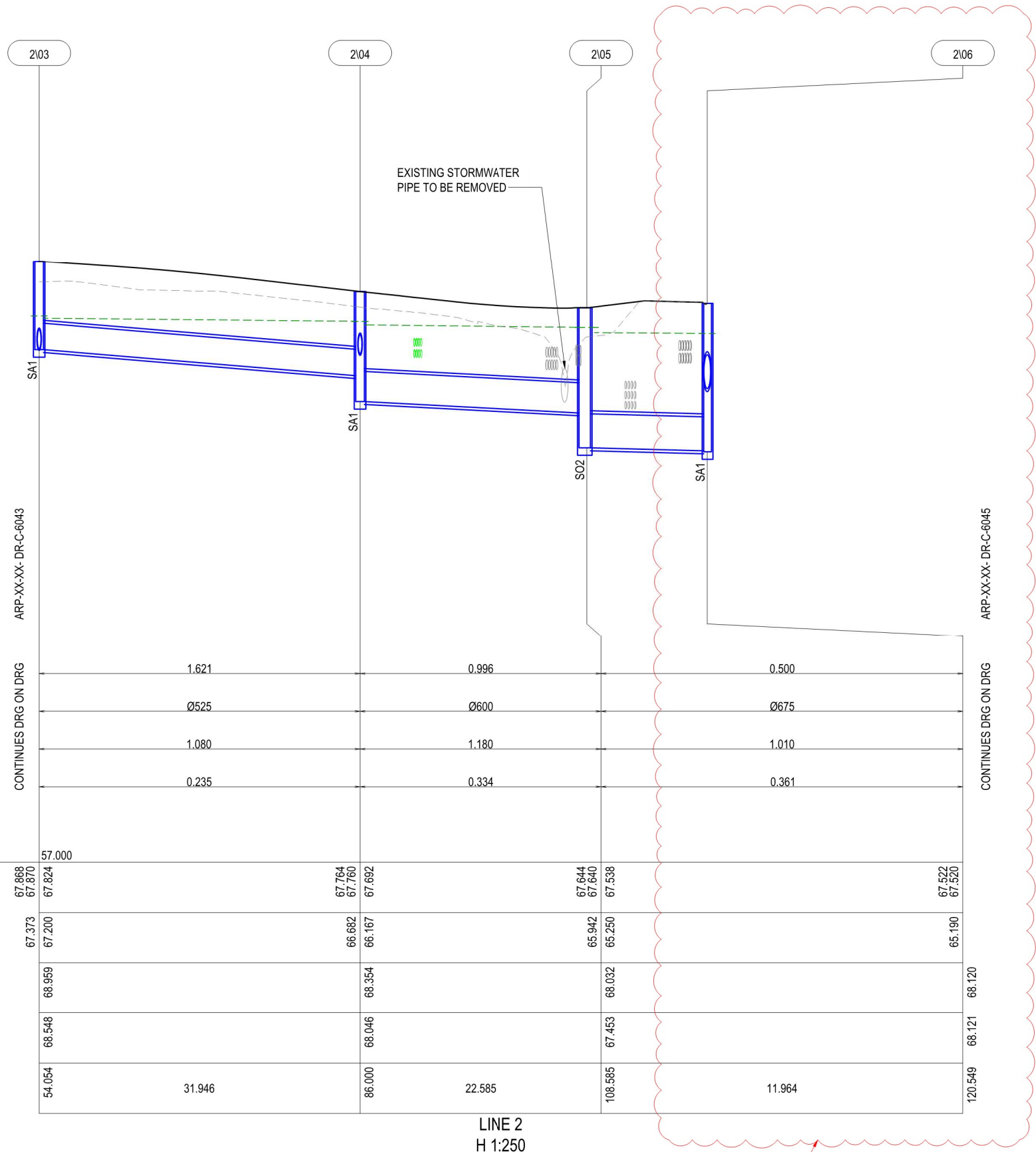

PIPE GRADE (%)

PIPE DIAMETER (mm)

5% AEP PIPE VELOCITY (m/s)

5% AEP PIPE FLOW (m³/s)

DATUM R.L.

HYDRAULIC GRADE LINE (m)
(5% AEP)

PIPE INVERT LEVELS (m)

DESIGN LEVELS (m)

EXISTING LEVELS (m)

CHAINAGE (m)

CONTINUES DRG ON DRG ARP-XX-XX-DR-C-6043

CONTINUES DRG ON DRG ARP-XX-XX-DR-C-6045

LINE 2
H 1:250
V 1:50

PROPOSED STORMWATER TO BE CONSTRUCTED BY OTHERS

NOTES

- FOR GENERAL NOTES REFER DRAWING No's ARU-XX-XX-DR-C-0006 TO ARU-XX-XX-DR-C-0007.
- ALL PROPOSED STORMWATER AND SEWER PIPES TO BE CLASS 4 RCP UNO.

KEYNOTES

LEGEND

- UTILITIES
- EXISTING UTILITIES
 - ELECTRICAL - MV
 - ELECTRICAL - LV
 - COMMUNICATION - METRO FIBRE
 - COMMUNICATION - ELV
 - FIREWATER
 - WATER
 - SEWER

REV	DATE	DESCRIPTION	DRN	ENG	CHK	APP
D	17NOV22	TENDER SET		PA	EA	TT LC
C	20OCT22	DESIGN DEVELOPMENT		PA	EA	TT LC
B	01SEP22	SCHEMATIC DESIGN		PA	EA	TT LC
A	18AUG22	ISSUED FOR SSSA		PA	EA	TT LC

CONSULTING ENGINEERS

ARUP

ARCHITECT

GENTON

PROJECT: ECHIDNA

TITLE: STORMWATER LONGITUDINAL SECTION SHEET 4

DRAWING NO.: ARP-XX-XX-DR-C-6044

SCALE: NOT TO SCALE AGILE No.: REV: D

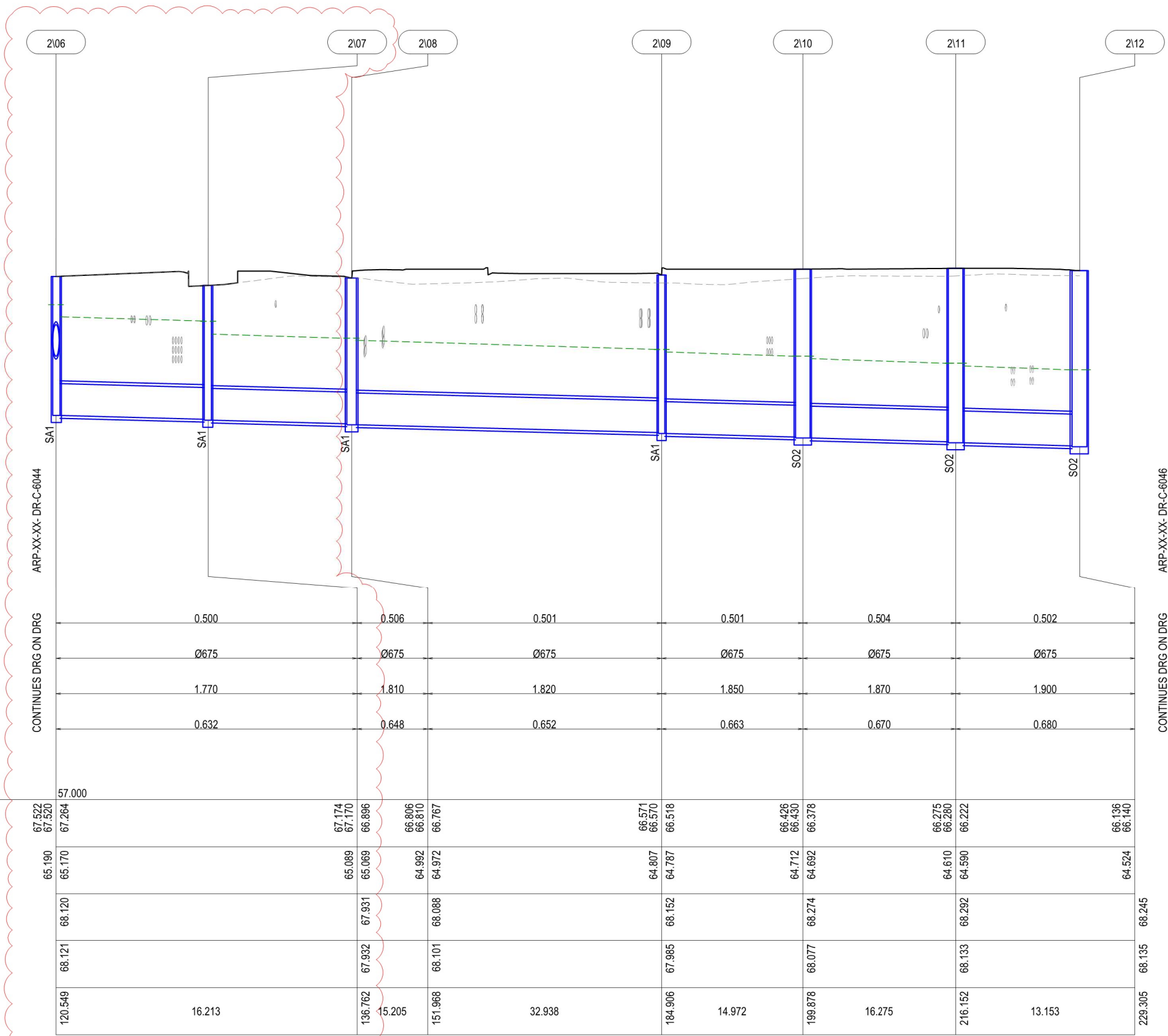

PROPOSED STORMWATER TO BE CONSTRUCTED BY OTHERS

LINE 2
H 1:250
V 1:50

PIPE GRADE (%)
 PIPE DIAMETER (mm)
 5% AEP PIPE VELOCITY (m/s)
 5% AEP PIPE FLOW (m³/s)
 DATUM R.L.
 HYDRAULIC GRADE LINE (m)
 (5% AEP)
 PIPE INVERT LEVELS (m)
 DESIGN LEVELS (m)
 EXISTING LEVELS (m)
 CHAINAGE (m)

CONTINUES DRG ON DRG

CONTINUES DRG ON DRG

Chainage	120.549	136.762	151.968	184.906	199.878	216.152	229.305
PIPE GRADE (%)		0.500	0.506	0.501	0.501	0.504	0.502
PIPE DIAMETER (mm)		Ø675	Ø675	Ø675	Ø675	Ø675	Ø675
5% AEP PIPE VELOCITY (m/s)		1.770	1.810	1.820	1.850	1.870	1.900
5% AEP PIPE FLOW (m³/s)		0.632	0.648	0.652	0.663	0.670	0.680
DATUM R.L.	57.000						
HYDRAULIC GRADE LINE (m) (5% AEP)	67.522 67.520 67.264	67.174 67.170 66.896	66.806 66.810 66.767	66.571 66.570 66.518	66.426 66.430 66.378	66.275 66.280 66.222	66.136 66.140
PIPE INVERT LEVELS (m)	65.190 65.170	65.089 65.069	64.992 64.972	64.807 64.787	64.712 64.692	64.610 64.590	64.524
DESIGN LEVELS (m)	68.120	67.931	68.088	68.152	68.274	68.292	68.245
EXISTING LEVELS (m)	68.121	67.932	68.101	67.985	68.077	68.133	68.135
CHAINAGE (m)	120.549	136.762	151.968	184.906	199.878	216.152	229.305

- NOTES
- FOR GENERAL NOTES REFER DRAWING No's ARU-XX-XX-DR-C-0006 TO ARU-XX-XX-DR-C-0007.
 - ALL PROPOSED STORMWATER AND SEWER PIPES TO BE CLASS 4 RCP UNO.

KEYNOTES

- LEGEND
- UTILITIES
- EXISTING UTILITIES
 - ELECTRICAL - MV
 - ELECTRICAL - LV
 - COMMUNICATION - METRO FIBRE
 - COMMUNICATION - ELV
 - FIREWATER
 - WATER
 - SEWER

REV	DATE	DESCRIPTION	DRN	ENG	CHK	APP
D	17NOV22	TENDER SET		PA	EA	TT LC
C	20OCT22	DESIGN DEVELOPMENT		PA	EA	TT LC
B	01SEP22	SCHEMATIC DESIGN		PA	EA	TT LC
A	18AUG22	ISSUED FOR SSDA		PA	EA	TT LC

CONSULTING ENGINEERS

ARUP

ARCHITECT

GENTON

PROJECT: ECHIDNA

TITLE: STORMWATER LONGITUDINAL SECTION SHEET 5

DRAWING NO.: ARP-XX-XX-DR-C-6045

SCALE: NOT TO SCALE

AGILE No.:

REV: D



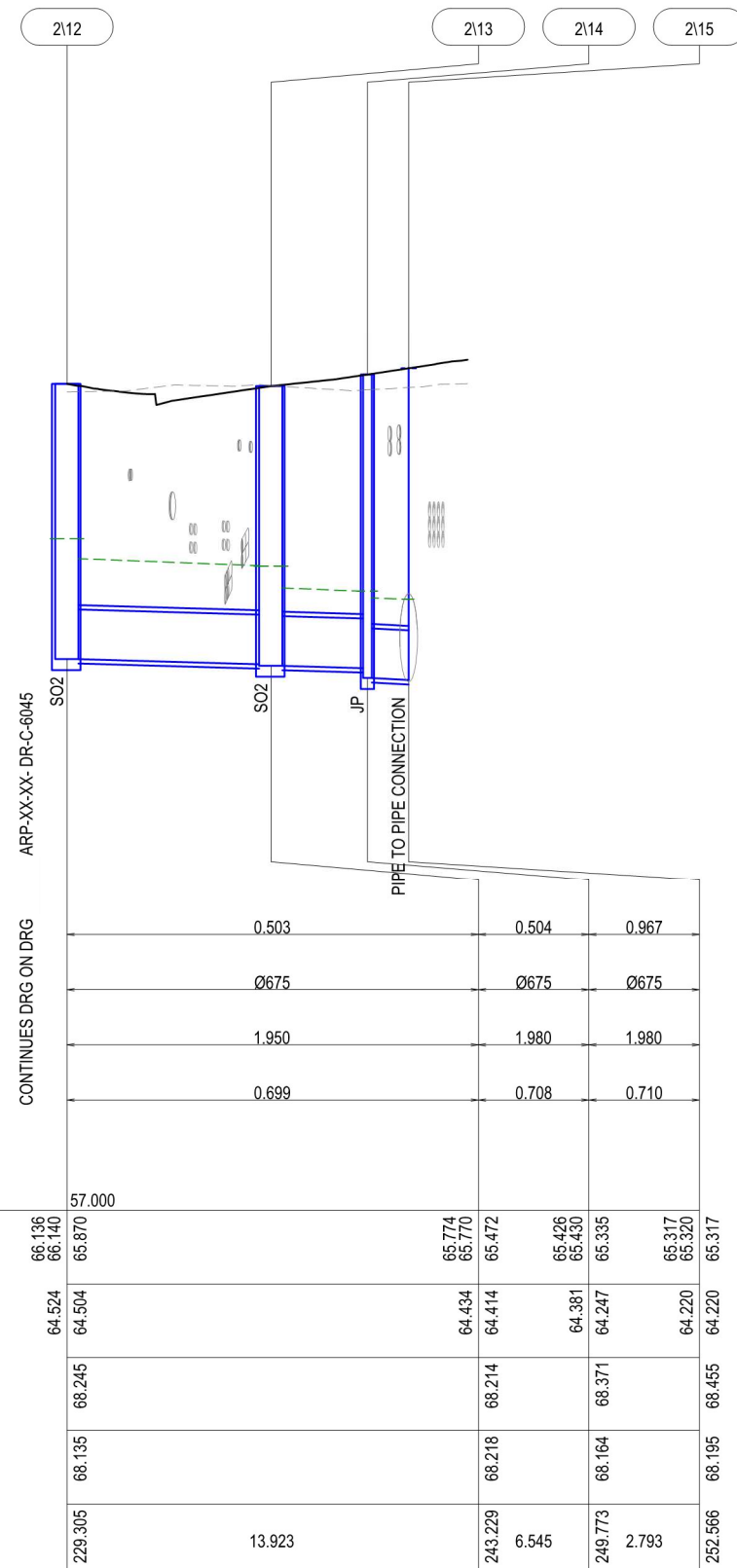

LINE 2
H 1:250
V 1:50

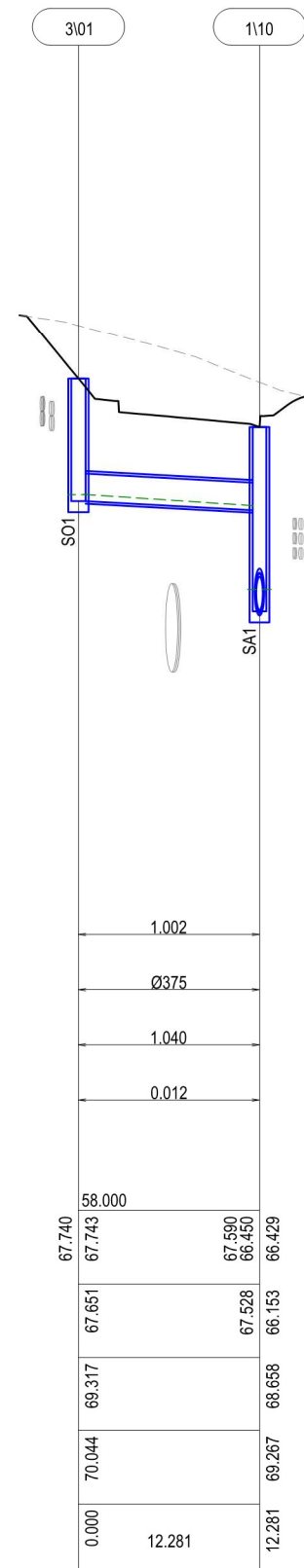

LINE 3
H 1:250
V 1:50

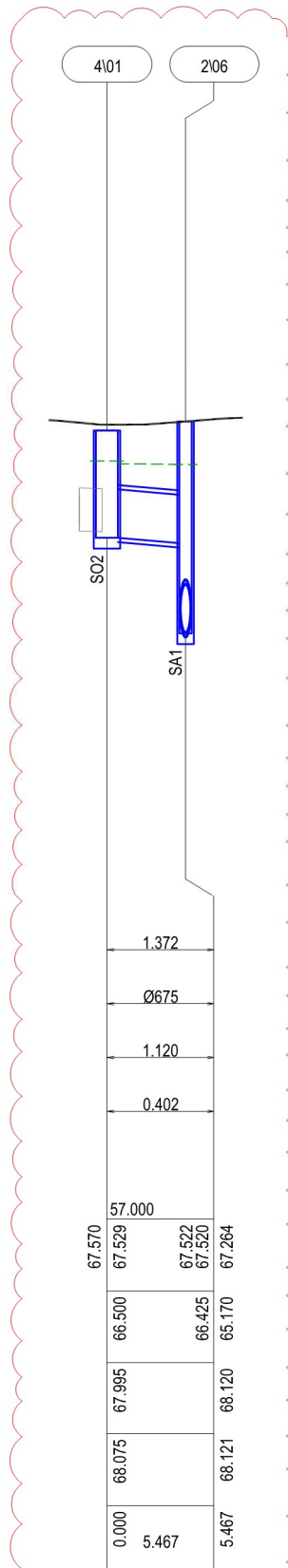

LINE 4
H 1:250
V 1:50

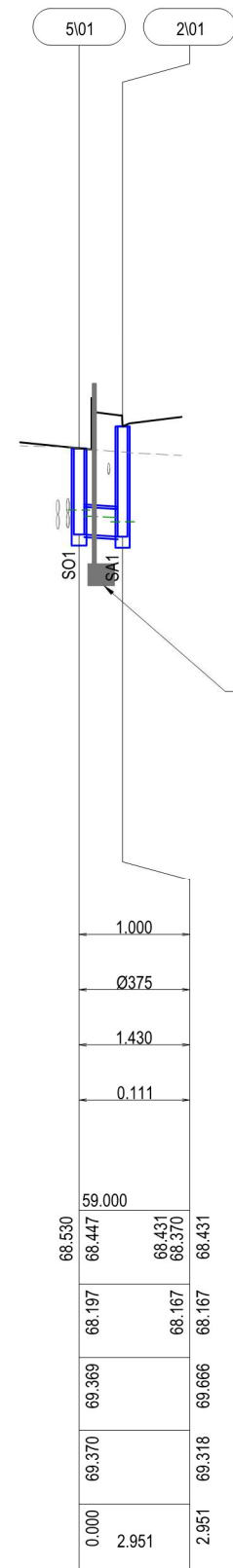

LINE 5
H 1:250
V 1:50

PROPOSED STORMWATER TO BE CONSTRUCTED BY OTHERS

FOR RETAINING WALL FOOTINGS REFER TO STRUCTURAL PACKAGE

NOTES

- FOR GENERAL NOTES REFER DRAWING No's ARU-XX-XX-DR-C-0006 TO ARU-XX-XX-DR-C-0007.
- ALL PROPOSED STORMWATER AND SEWER PIPES TO BE CLASS 4 RCP UNO.

KEYNOTES

LEGEND

- UTILITIES
- EXISTING UTILITIES
 - ELECTRICAL - MV
 - ELECTRICAL - LV
 - COMMUNICATION - METRO FIBRE
 - COMMUNICATION - ELV
 - FIREWATER
 - WATER
 - SEWER

REV	DATE	DESCRIPTION	DRN	ENG	CHK	APP
D	17NOV22	TENDER SET		PA	EA	TT LC
C	20OCT22	DESIGN DEVELOPMENT		PA	EA	TT LC
B	01SEP22	SCHEMATIC DESIGN		PA	EA	TT LC
A	18AUG22	ISSUED FOR SSDA		PA	EA	TT LC

CONSULTING ENGINEERS

ARUP

ARCHITECT

GENTON

PROJECT: ECHIDNA

TITLE: STORMWATER LONGITUDINAL SECTION SHEET 6

DRAWING NO.: ARP-XX-XX-DR-C-6046

SCALE: NOT TO SCALE AGILE No.: REV: D



NOTES

- FOR GENERAL NOTES REFER DRAWING No's ARU-XX-XX-DR-C-0006 TO ARU-XX-XX-DR-C-0007.
- ALL PROPOSED STORMWATER AND SEWER PIPES TO BE CLASS 4 RCP UNO.

KEYNOTES

LEGEND

- UTILITIES
- EXISTING UTILITIES
 - ELECTRICAL - MV
 - ELECTRICAL - LV
 - COMMUNICATION - METRO FIBRE
 - COMMUNICATION - ELV
 - FIREWATER
 - WATER
 - SEWER

FOR RETAINING WALL FOOTINGS REFER TO STRUCTURAL PACKAGE

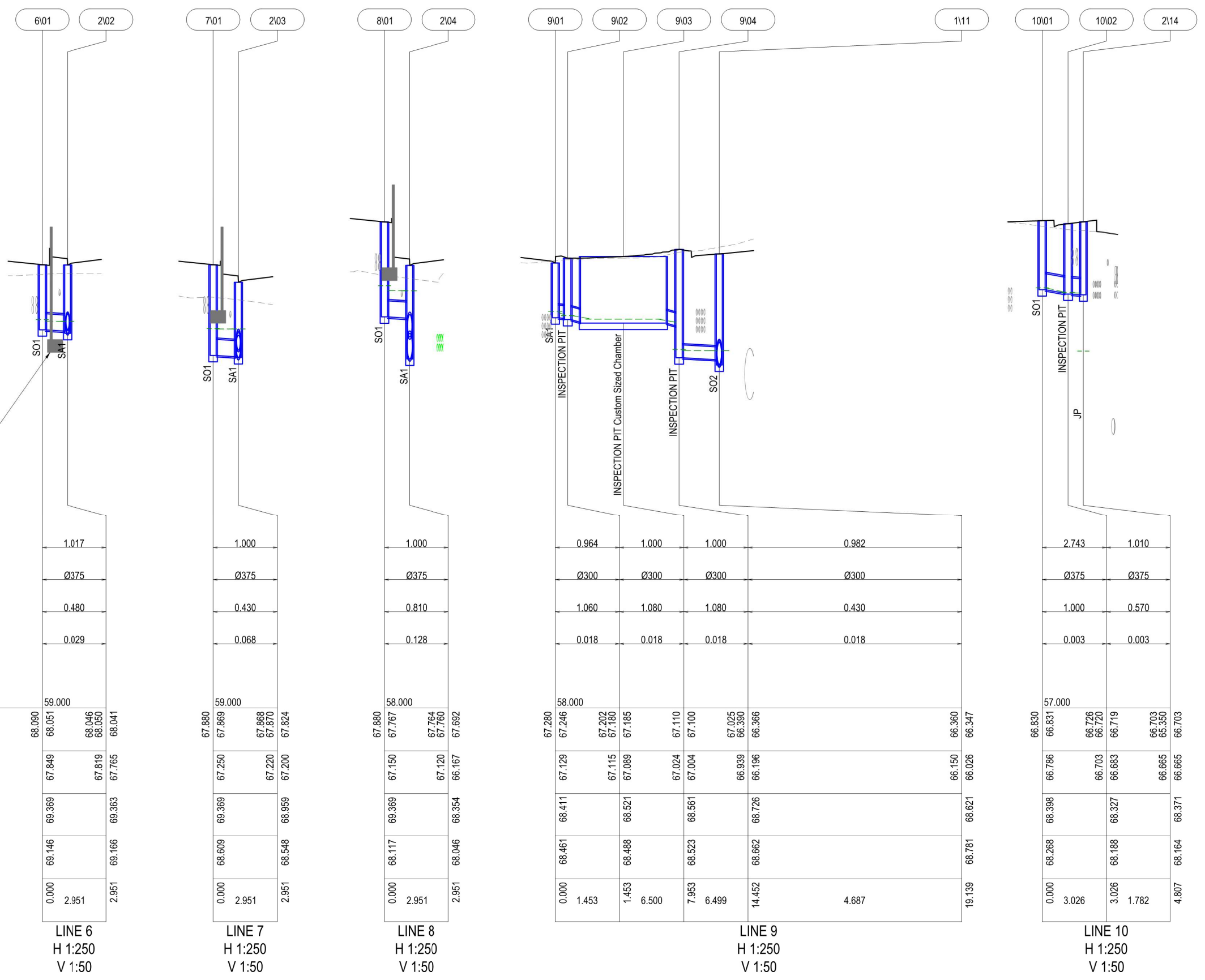

D	17NOV22	TENDER SET	PA	EA	TT	LC
C	20OCT22	DESIGN DEVELOPMENT	PA	EA	TT	LC
REV	DATE	DESCRIPTION	DRN	ENG	CHK	APP

CONSULTING ENGINEERS

ARUP

ARCHITECT

GENTON

PROJECT: ECHIDNA

TITLE: STORMWATER LONGITUDINAL SECTION SHEET 7

DRAWING NO.: ARP-XX-XX-DR-C-6047

SCALE: A1 NOT TO SCALE

AGILE No.: D

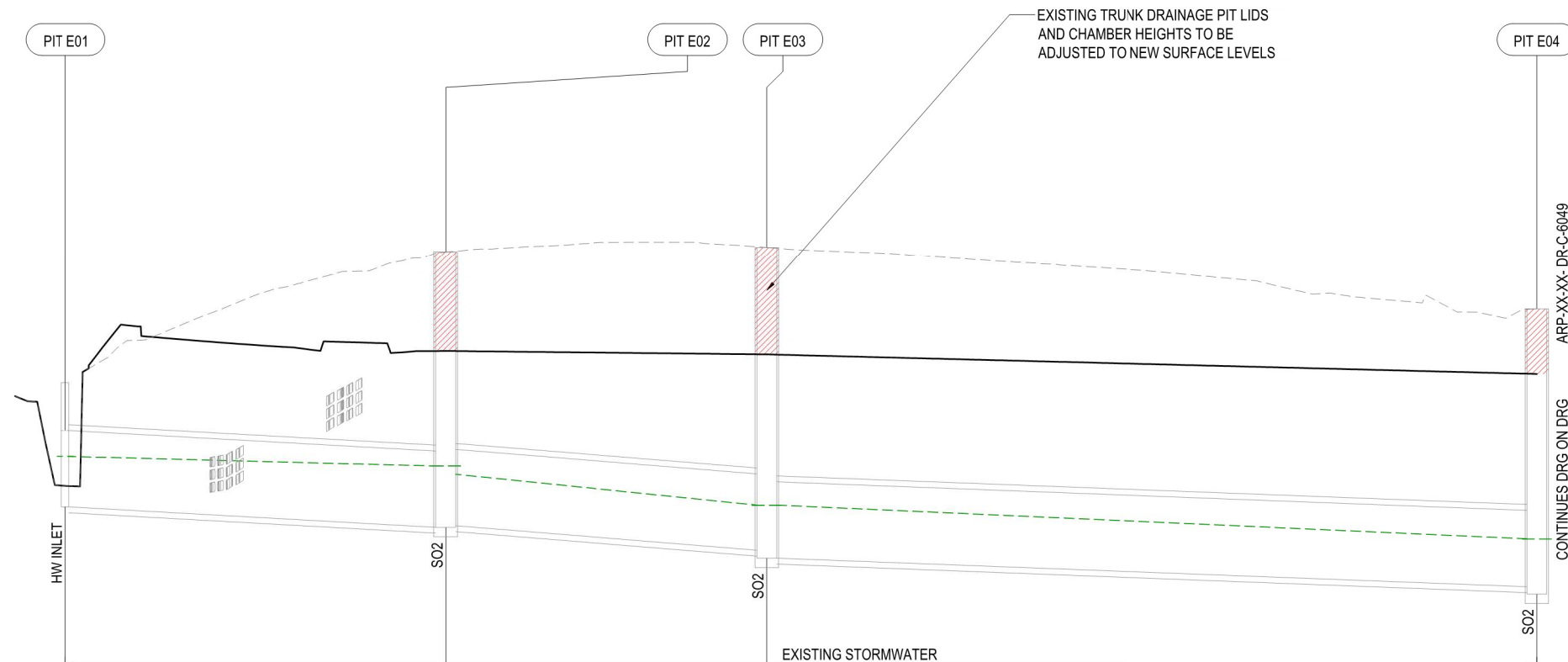

PIPE GRADE (%)
 PIPE DIAMETER (mm)
 5% AEP PIPE VELOCITY (m/s)
 5% AEP PIPE FLOW (m³/s)
 DATUM R.L.
 HYDRAULIC GRADE LINE (m)
 (5% AEP)
 PIPE INVERT LEVELS (m)
 DESIGN LEVELS (m)
 EXISTING LEVELS (m)
 CHAINAGE (m)

		1.069		1.522				0.743
		Ø1200		Ø1200				Ø1200
		3.070		3.250				3.200
		2.437		2.427				2.399
DATUM R.L.	58.000							
HYDRAULIC GRADE LINE (m) (5% AEP)	67.540 67.539		67.388 67.390	67.258	66.773 66.770	66.773		66.244 66.240
PIPE INVERT LEVELS (m)	66.745		66.425 66.425	66.450	66.065 65.940	65.940		65.490
DESIGN LEVELS (m)	67.945		70.764		70.835			69.859
EXISTING LEVELS (m)	67.076		70.764		70.836			69.859
CHAINAGE (m)	0.000	29.946	29.946 25.290	55.236		60.597		115.833

LINE T
 H 1:250
 V 1:50

- NOTES
- FOR GENERAL NOTES REFER DRAWING No's ARU-XX-XX-DR-C-0006 TO ARU-XX-XX-DR-C-0007.
 - ALL PROPOSED STORMWATER AND SEWER PIPES TO BE CLASS 4 RCP UNO.

KEYNOTES

- LEGEND
- UTILITIES
- EXISTING UTILITIES
 - ELECTRICAL - MV
 - ELECTRICAL - LV
 - COMMUNICATION - METRO FIBRE
 - COMMUNICATION - ELV
 - FIREWATER
 - WATER
 - SEWER

D	17NOV22	TENDER SET	PA	EA	TT	LC
A	20OCT22	DESIGN DEVELOPMENT	PA	EA	TT	LC
REV	DATE	DESCRIPTION	DRN	ENG	CHK	APP

CONSULTING ENGINEERS

ARUP

ARCHITECT

GENTON

PROJECT: ECHIDNA

TITLE: STORMWATER LONGITUDINAL SECTION SHEET 8

DRAWING NO.: ARP-XX-XX-DR-C-6048

SCALE: NOT TO SCALE

AGILE No.: A1

REV: D



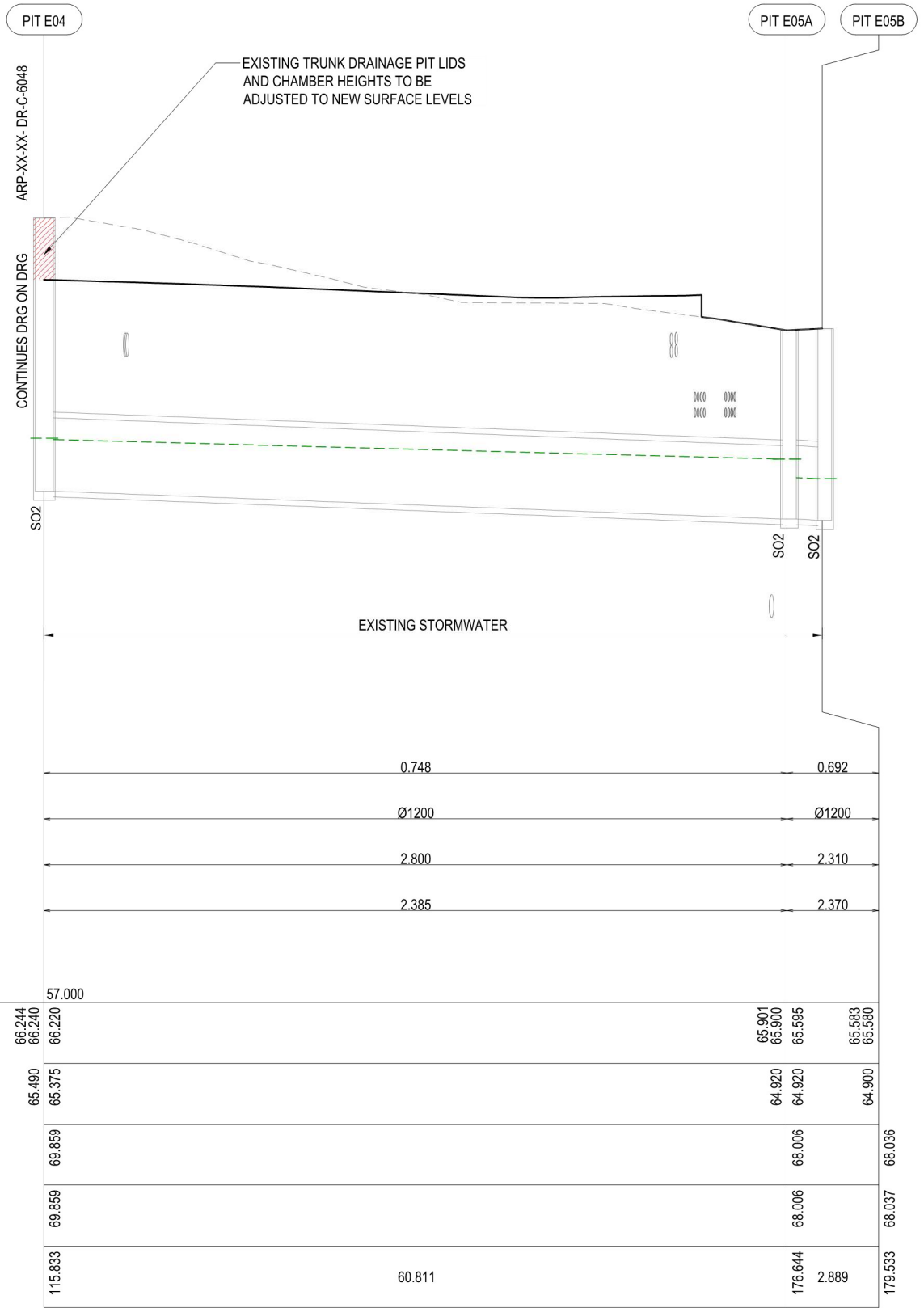

PIPE GRADE (%)

PIPE DIAMETER (mm)

5% AEP PIPE VELOCITY (m/s)

5% AEP PIPE FLOW (m³/s)

DATUM R.L.

HYDRAULIC GRADE LINE (m)
(5% AEP)

PIPE INVERT LEVELS (m)

DESIGN LEVELS (m)

EXISTING LEVELS (m)

CHAINAGE (m)

LINE T
H 1:250
V 1:50

NOTES

- FOR GENERAL NOTES REFER DRAWING No's ARU-XX-XX-DR-C-0006 TO ARU-XX-XX-DR-C-0007.
- ALL PROPOSED STORMWATER AND SEWER PIPES TO BE CLASS 4 RCP UNO.

KEYNOTES

LEGEND

- UTILITIES
- EXISTING UTILITIES
 - ELECTRICAL - MV
 - ELECTRICAL - LV
 - COMMUNICATION - METRO FIBRE
 - COMMUNICATION - ELV
 - FIREWATER
 - WATER
 - SEWER

REV	DATE	DESCRIPTION	DRN	ENG	CHK	APP
D	17NOV22	TENDER SET	PA	EA	TT	LC
A	20OCT22	DESIGN DEVELOPMENT	PA	EA	TT	LC

CONSULTING ENGINEERS

ARUP

ARCHITECT

GENTON

PROJECT: ECHIDNA

TITLE: STORMWATER LONGITUDINAL SECTION SHEET 9

DRAWING NO.: ARP-XX-XX-DR-C-6049

SCALE: NOT TO SCALE

AGILE No.: D



STRUCTURE NAME	STRUCTURE TYPE	EASTING	NORTHING	PIT SETOUT LEVEL (m AHD)	PIT DEPTH (m)	PIT SUMP LEVEL (m AHD)	DRAWING REFERENCE	COMMENTS
01101	SA1	299986.053	6256637.338	69.629	1.116	68.513	R0220-01	INSTALL OCEANGUARD FILTER BASKET IN PIT
01102	SA1	299947.096	6256630.303	69.466	1.203	68.263	R0220-01	INSTALL OCEANGUARD FILTER BASKET IN PIT
01103	SA1	299935.325	6256635.189	69.373	1.193	68.180	R0220-01	INSTALL OCEANGUARD FILTER BASKET IN PIT
01104	SA1	299914.651	6256632.832	69.413	1.513	67.900	R0220-01	INSTALL OCEANGUARD FILTER BASKET IN PIT
01105	JP	299907.616	6256639.555	69.743	1.961	67.782	R0220-29	
01106	JP	299906.308	6256650.807	69.751	2.573	67.178	R0220-29	
01107	SA1	299900.801	6256656.393	69.091	2.011	67.080	R0220-01	INSTALL OCEANGUARD FILTER BASKET IN PIT
01108	SA1	299896.766	6256688.868	68.928	2.196	66.732	R0220-01	INSTALL OCEANGUARD FILTER BASKET IN PIT
01109	SA1	299893.555	6256714.716	68.798	2.347	66.451	R0220-01	INSTALL OCEANGUARD FILTER BASKET IN PIT
01110	SA1	299890.134	6256742.251	68.658	2.505	66.153	R0220-01	INSTALL OCEANGUARD FILTER BASKET IN PIT
01111	SO2	299888.837	6256752.827	68.621	2.595	66.026	R0220-22/23	INSTALL OCEANGUARD FILTER BASKET IN PIT
01112	SA1	299886.435	6256772.382	68.450	2.920	65.530	R0220-01	INSTALL OCEANGUARD FILTER BASKET IN PIT
01113	JP	299890.812	6256772.906	68.468	4.268	64.200	R0220-29	CONNECTION INTO EXISTING COUNCIL STORMWATER CULVERT
02101	SA1	300006.973	6256664.662	69.666	1.519	68.147	R0220-01	INSTALL OCEANGUARD FILTER BASKET IN PIT
02102	SA1	300004.234	6256687.498	69.363	1.598	67.765	R0220-01	INSTALL OCEANGUARD FILTER BASKET IN PIT
02103	SA1	300000.536	6256718.331	68.959	1.759	67.200	R0220-01	INSTALL OCEANGUARD FILTER BASKET IN PIT
02104	SA1	299996.732	6256750.050	68.354	2.187	66.167	R0220-01	INSTALL OCEANGUARD FILTER BASKET IN PIT
02105	SO2	299994.407	6256772.515	68.032	2.782	65.250	R0220-22/23	INSTALL OCEANGUARD FILTER BASKET IN PIT. HYDROCARBON SENSOR ALARM AND AUTOMATIC SHUT OFF VALVE INSTALLED IN PIT. SHUTOFF VALVE IS TYPICALLY OPEN AND CLOSES UPON DETECTION OF HYDROCARBON.
02106	SA1	300005.479	6256777.047	68.120	2.950	65.170	R0220-01	INSTALL OCEANGUARD FILTER BASKET IN PIT
02107	SA1	300003.549	6256793.145	67.931	2.862	65.069	R0220-01	INSTALL OCEANGUARD FILTER BASKET IN PIT
02108	SA1	299988.452	6256791.329	68.088	3.116	64.972	R0220-01	INSTALL OCEANGUARD FILTER BASKET IN PIT
02109	SA1	299955.7498	6256787.396	68.152	3.365	64.787	R0220-01	INSTALL OCEANGUARD FILTER BASKET IN PIT
02110	SO2	299940.885	6256785.608	68.274	3.582	64.692	R0220-22/23	INSTALL OCEANGUARD FILTER BASKET IN PIT
02111	SO2	299924.995	6256782.089	68.292	3.702	64.590	R0220-22/23	INSTALL OCEANGUARD FILTER BASKET IN PIT
02112	SO2	299911.936	6256780.523	68.245	3.741	64.504	R0220-22/23	INSTALL OCEANGUARD FILTER BASKET IN PIT
02113	SO2	299898.763	6256785.030	68.214	3.800	64.414	R0220-22/23	INSTALL OCEANGUARD FILTER BASKET IN PIT
02114	JP	299892.263	6256784.264	68.371	4.124	64.247	R0220-29	INSTALL OCEANGUARD FILTER BASKET IN PIT
02115	PIPE TO PIPE CONNECTION	299889.489	6256783.937	64.22 (IL)				CONNECTION INTO EXISTING COUNCIL STORMWATER CULVERT
03101	SO1	299882.352	6256732.751	69.317	1.666	67.651	R0220-21/23	INSTALL OCEANGUARD FILTER BASKET IN PIT
04101	EXISTING	300005.847	6256771.592	67.995	1.495	66.500	EXISTING	CONNECTION FROM EXISTING STORMWATER BY OTHERS
05101	SO1	300004.043	6256664.310	69.369	1.172	68.197	R0220-21/23	INSTALL OCEANGUARD FILTER BASKET IN PIT
06101	SO1	300001.304	6256687.147	69.369	1.520	67.849	R0220-21/23	INSTALL OCEANGUARD FILTER BASKET IN PIT
07101	SO1	299997.606	6256717.980	69.369	2.119	67.250	R0220-21/23	INSTALL OCEANGUARD FILTER BASKET IN PIT
08101	SO1	299993.802	6256749.698	69.369	2.219	67.150	R0220-21/23	INSTALL OCEANGUARD FILTER BASKET IN PIT
09101	SA1	299890.441	6256766.141	68.411	1.282	67.129	R0220-01	INSTALL OCEANGUARD FILTER BASKET IN PIT
09102	JP	299891.883	6256766.319	68.521	1.432	67.089	R0220-29	
09103	SPEL Puraceptor	299892.678	6256759.868	68.561	1.557	67.004	N/A	
09104	JP	299893.486	6256753.419	68.726	2.530	66.196	R0220-29	
10101	SO1	299892.837	6256779.491	68.398	1.612	66.786	R0220-21/23	INSTALL OCEANGUARD FILTER BASKET IN PIT
10102	JP	299892.476	6256782.495	68.327	1.644	66.683	R0220-29	HYDROCARBON SENSOR ALARM AND AUTOMATIC SHUT OFF VALVE INSTALLED IN PIT. SHUTOFF VALVE IS TYPICALLY OPEN AND CLOSES UPON DETECTION OF HYDROCARBON.
PIT E01	EXISTING	299916.4978	6256620.954	66.745	1.2	66.745	N/A	EXISTING STORMWATER TRUNK MAIN
PIT E02	EXISTING	299900.781	6256646.444	69.197	4.339	66.425	N/A	EXISTING STORMWATER TRUNK MAIN
PIT E03	EXISTING	299894.153	6256670.85	69.143	4.895	65.94	N/A	EXISTING STORMWATER TRUNK MAIN
PIT E04	EXISTING	299886.9377	6256731.016	68.835	4.484	65.375	N/A	EXISTING STORMWATER TRUNK MAIN
PIT E05A	EXISTING	299882.2626	6256791.647	68.006	3.086	64.92	N/A	EXISTING STORMWATER TRUNK MAIN
PIT E05B	EXISTING	299879.4443	6256791.011	68.036	3.136	64.9	N/A	EXISTING STORMWATER TRUNK MAIN

PROPOSED STORMWATER TO BE CONSTRUCTED BY OTHERS

PROPOSED STORMWATER TO BE CONSTRUCTED BY OTHERS

NOTES
1. ALL PIT LIDS AND COVERS TO BE CLASS D UNLESS NOTED OTHERWISE.

KEYNOTES

LEGEND

REV	DATE	DESCRIPTION	DRN	ENG	CHK	APP
D	17NOV22	TENDER SET		PA	EA	TT LC
C	20OCT22	DESIGN DEVELOPMENT		PA	EA	TT LC
B	01SEP22	SCHEMATIC DESIGN		PA	EA	TT LC
A	18AUG22	ISSUED FOR SSDA		PA	EA	TT LC

CONSULTING ENGINEERS

ARUP

ARCHITECT

GENTON

PROJECT: ECHIDNA

TITLE: STORMWATER PIT SCHEDULE SHEET 1

DRAWING NO.: ARP-XX-XX-DR-C-6081

SCALE: A1 NOT TO SCALE | AGILE No.: | REV: D

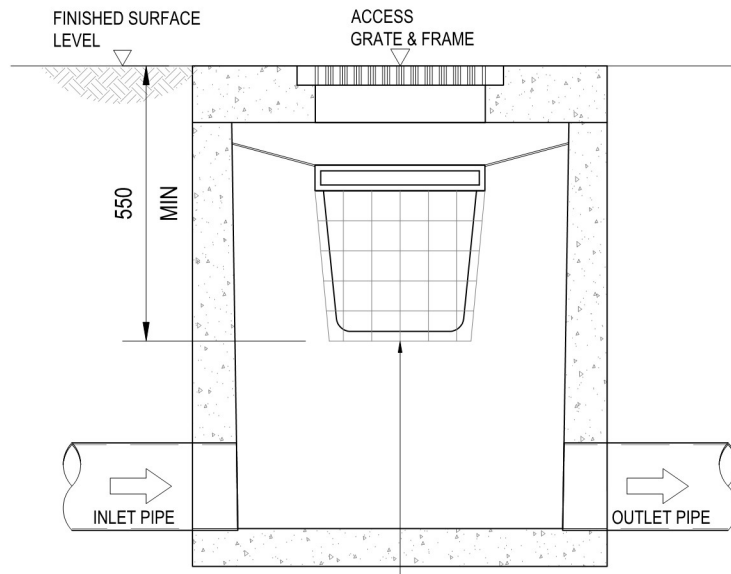

LITTER BASKET IN GULLY PIT CONFIGURATION
NOT TO SCALE

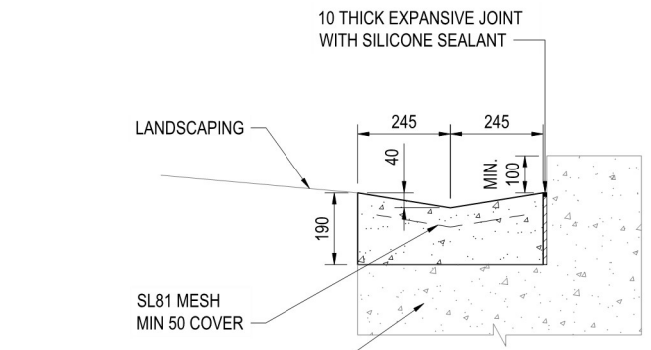

CONCRETE CHANNEL
SCALE 1:10

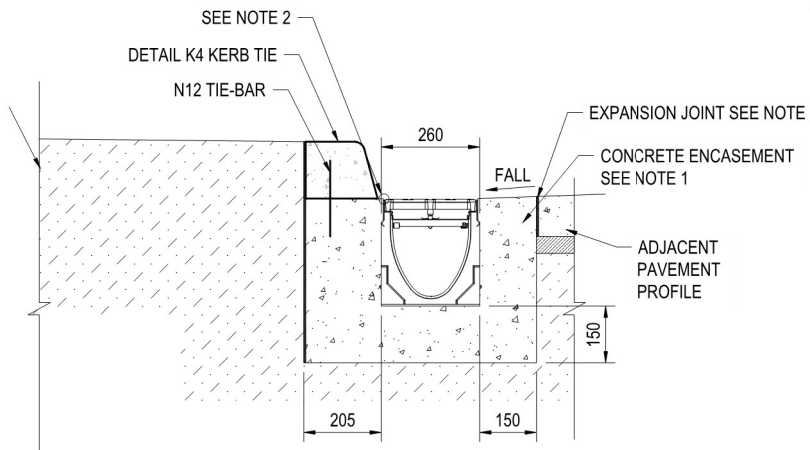

S200K ACO SLOPED CHANNEL GRATED DRAIN AND KERB DETAIL ACO S200K CLASS D
SCALE 1:10

- NOTES:
- SPECIFIC SITE CONDITIONS MAY REQUIRE AN INCREASE IN THE CONCRETE ENCASEMENT DIMENSIONS AND/OR REINFORCEMENT. IT IS THE CUSTOMER'S RESPONSIBILITY TO ENSURE THE CONCRETE ENCASEMENT IS DESIGNED FOR THE APPLICATION. A MINIMUM CONCRETE STRENGTH OF 25MPa IS RECOMMENDED. THE CONCRETE SHOULD BE VIBRATED TO ELIMINATE AIR POCKETS. ENGINEERING ADVICE MAY BE REQUIRED.
 - THE FINISHED LEVEL OF THE CONCRETE ENCASEMENT MUST BE APPROXIMATELY 3mm ABOVE THE TOP OF THE CHANNEL EDGE.
 - EXPANSION AND CRACK CONTROL JOINTS ARE RECOMMENDED TO PROTECT THE CHANNEL AND THE CONCRETE ENCASEMENT. ENGINEERING ADVICE MAY BE REQUIRED.
 - FOR FURTHER DETAILS, REFER TO ACO'S DESIGN & SITE INSTALLATION FILES AT WWW.ACODRAIN.COM.AU/RESOURCES.

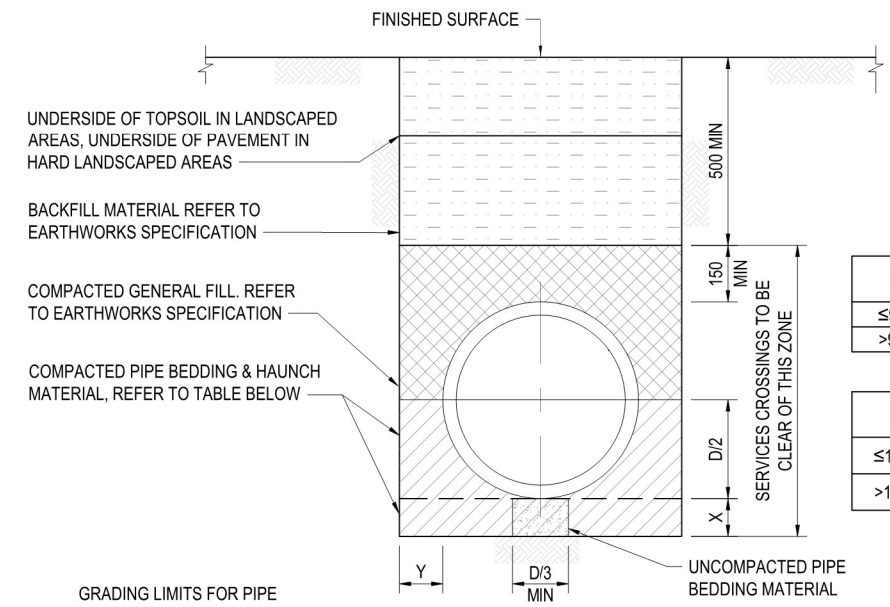

D	Y (mm)
≤900	150
>900	D/6

D	X (mm)
≤1500	100 (MIN)
>1500	150 (MIN)

GRADING LIMITS FOR PIPE BEDDING HAUNCH MATERIAL

SIEVE SIZE (mm)	WEIGHT PASSING (%)
19.0	100
2.36	100-50
0.60	90-20
0.30	60-10
0.15	25-0
0.075	10-0

GRANULAR BACK FILL TYPICAL SECTION
TYPE HS3
SCALE 1:10

PIPE BEDDING & HAUNCH MATERIAL COMPACTION REQUIREMENTS

TYPE	MIN STD COMPACTION
COHESIVE	50% ^{*1}
COHENSIONLESS	85% ^{*2}

*1 IN ACCORDANCE WITH AS3725-2007

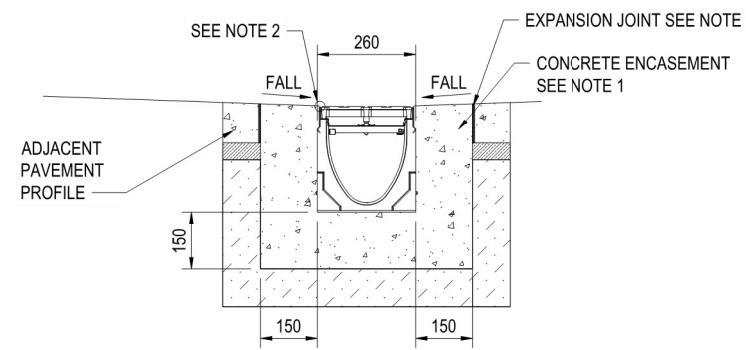

S200K ACO SLOPED CHANNEL GRATED DRAIN DETAIL
ACO S200K CLASS D
SCALE 1:10

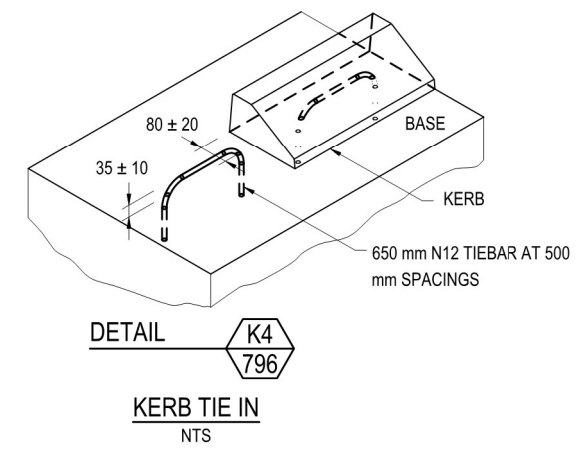

NOTES

- NOTE**
- ALL STORMWATER PIT COMPONENTS TO MEET AUSTRROADS T44 LOAD RATING WITH 0.0m TO 2.0m FILL MAXIMUM (CLASS E).

KEYNOTES

LEGEND

REV	DATE	DESCRIPTION	DRN	ENG	CHK	APP
D	17NOV22	TENDER SET		PA	EA	TT LC
C	20OCT22	DESIGN DEVELOPMENT		PA	EA	TT LC
B	01SEP22	SCHEMATIC DESIGN		PA	EA	TT LC
A	18AUG22	ISSUED FOR SSDA		PA	EA	TT LC

CONSULTING ENGINEERS

ARUP

ARCHITECT

GENTON

PROJECT: ECHIDNA

TITLE: STORMWATER DETAILS SHEET 1

DRAWING NO.: ARP-XX-XX-DR-C-6091

SCALE: A1 1:10mm AGILE No.: REV: D

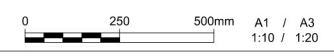

NOTE

- 1. ALL STORMWATER PIT COMPONENTS TO MEET AUSTRROADS T44 LOAD RATING WITH 0.0m TO 2.0m FILL MAXIMUM (CLASS E).

KEYNOTES

LEGEND

D	17NOV22	TENDER SET	PA	EA	TT	LC
C	20OCT22	DESIGN DEVELOPMENT	PA	EA	TT	LC
REV	DATE	DESCRIPTION	DRN	ENG	CHK	APP

CONSULTING ENGINEERS

ARUP

ARCHITECT

GENTON

PROJECT: ECHIDNA

TITLE: STORMWATER DETAILS SHEET 2

DRAWING NO.: ARP-XX-XX-DR-C-6092

SCALE: A1 1:10mm	AGILE No.:	REV: D
------------------	------------	--------

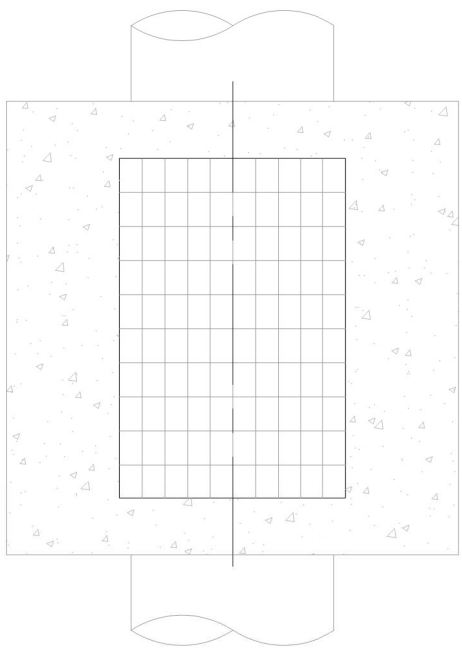

PLAN SCALE NTS

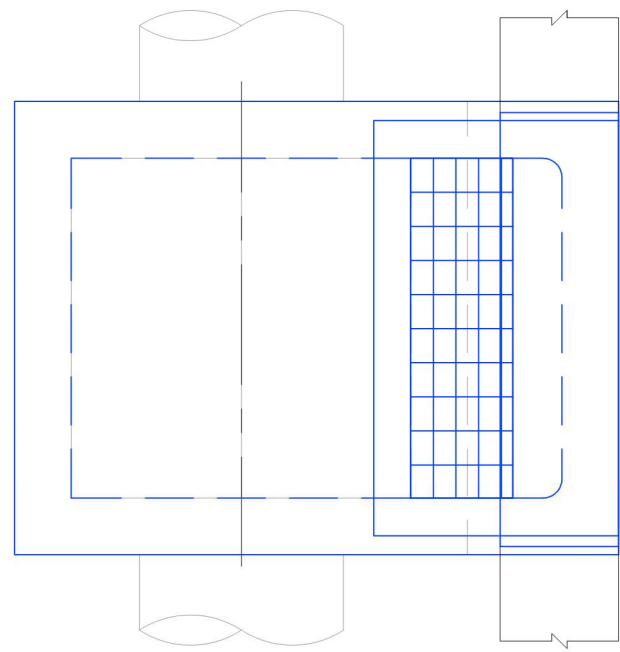
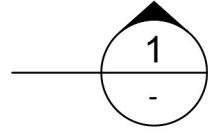

PLAN SCALE NTS

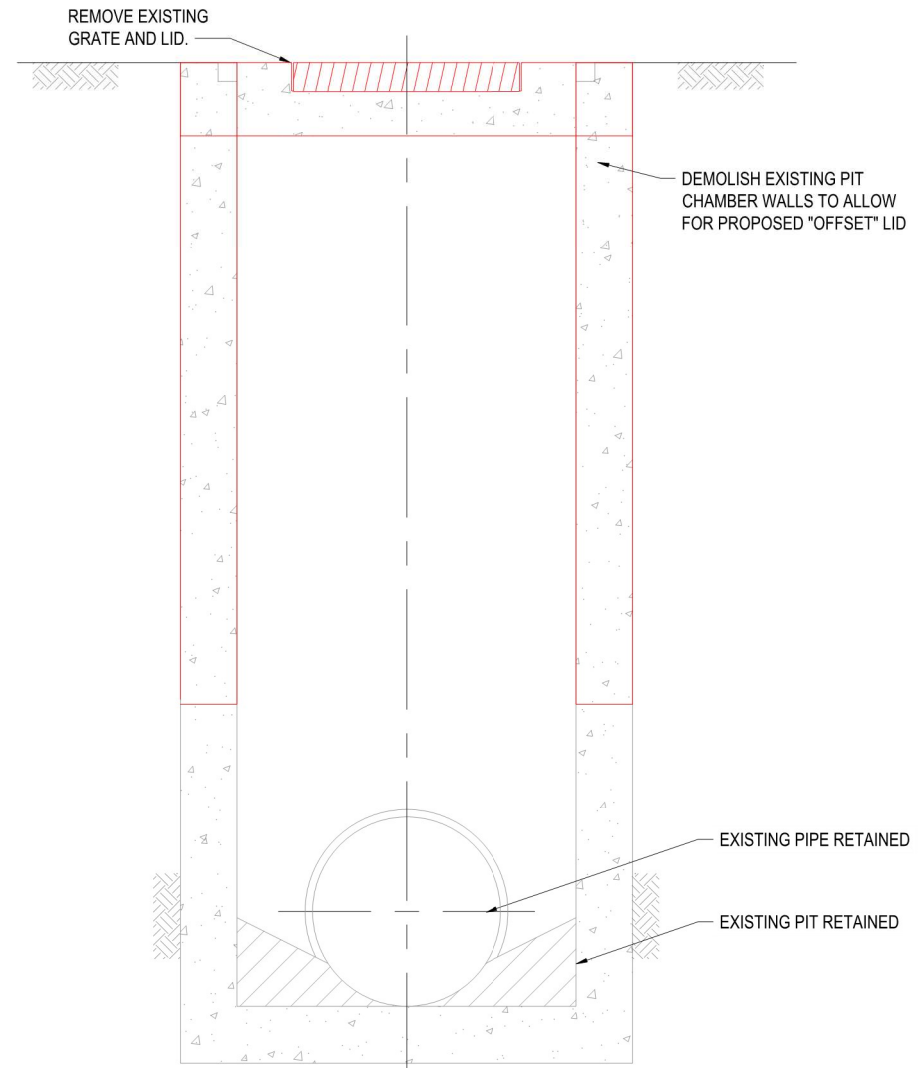
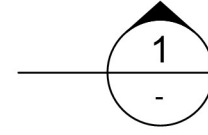

1) DEMOLISH EXISTING STORMWATER GRATED PIT LID
SECTION 1
SCALE NTS

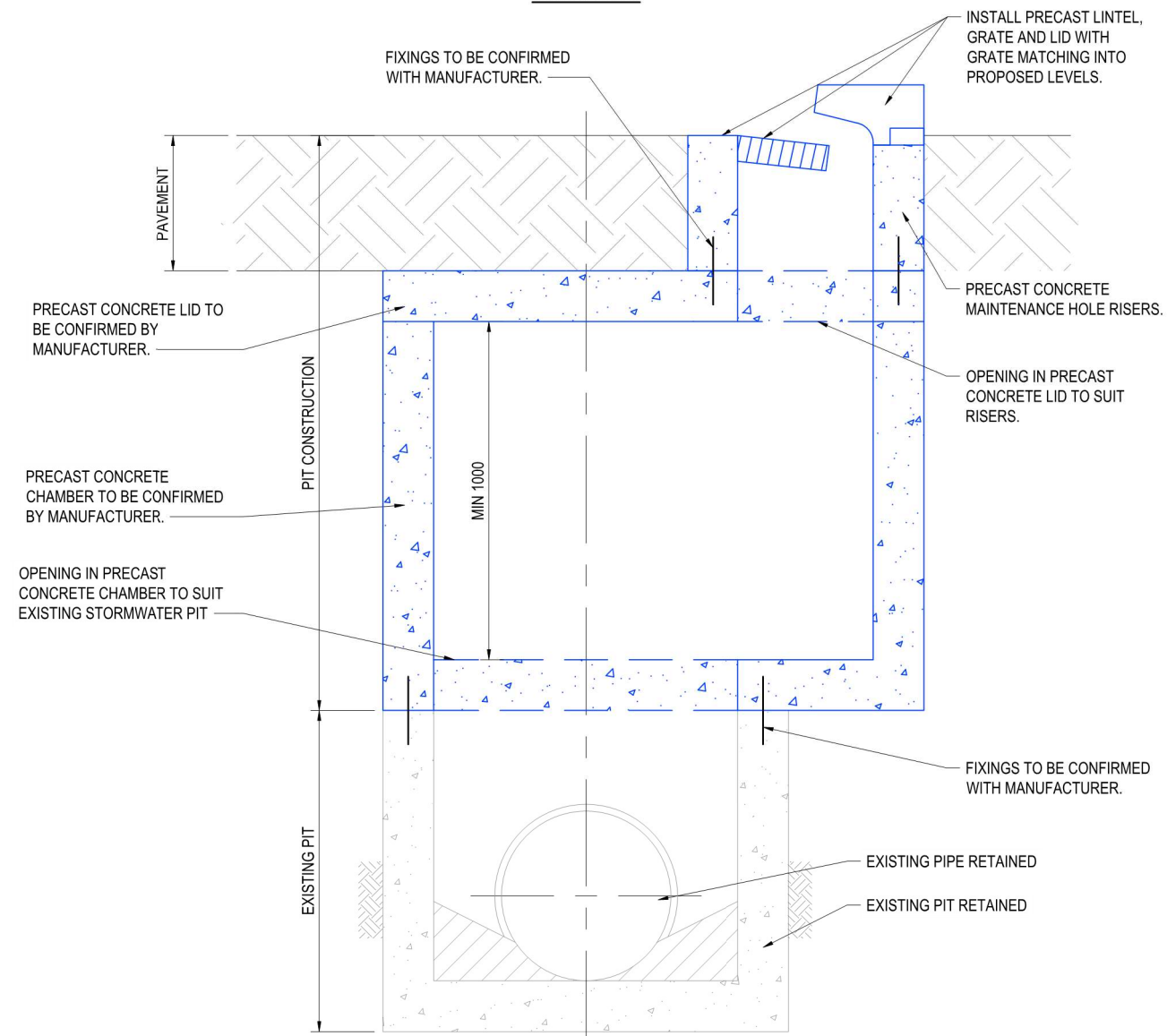

2) "OFFSET" CHAMBER, KERB INLET PIT LID, LINTEL AND GRATE INSTALLATION
SECTION 1
SCALE NTS